

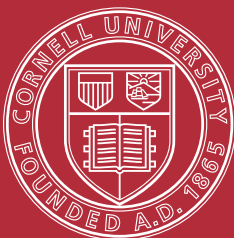

Preserving Books in Your Home Library



Cornell University
Library



Preserving Books in Your Home Library

Although few people have a home library as grand as the A.D. White Library pictured on the front of this brochure, many of us do have collections that we find meaningful. They probably consist of reference books, cookbooks, favorite works of fiction and non-fiction, and perhaps books saved from our childhoods. Although some of the books in our personal collections may be ephemeral, such as a best-selling mystery bought for a vacation, many of our books are like close friends that we hope to keep with us for the rest of our lives. This brochure will help you care for both your treasures and your “quick reads.”

Table of Contents

Parts of the Book	4
How Books Are Constructed	5
Caring for Your Books	7
Types of Books and Their Inherent Weaknesses	15
Repairing Books	23
Common Forms of Damage: What You Can Do About Them	25
Enclosures	34
In Case of Disaster	35
Suppliers	36
Additional Reading	37
Resources	38



Parts of the Book

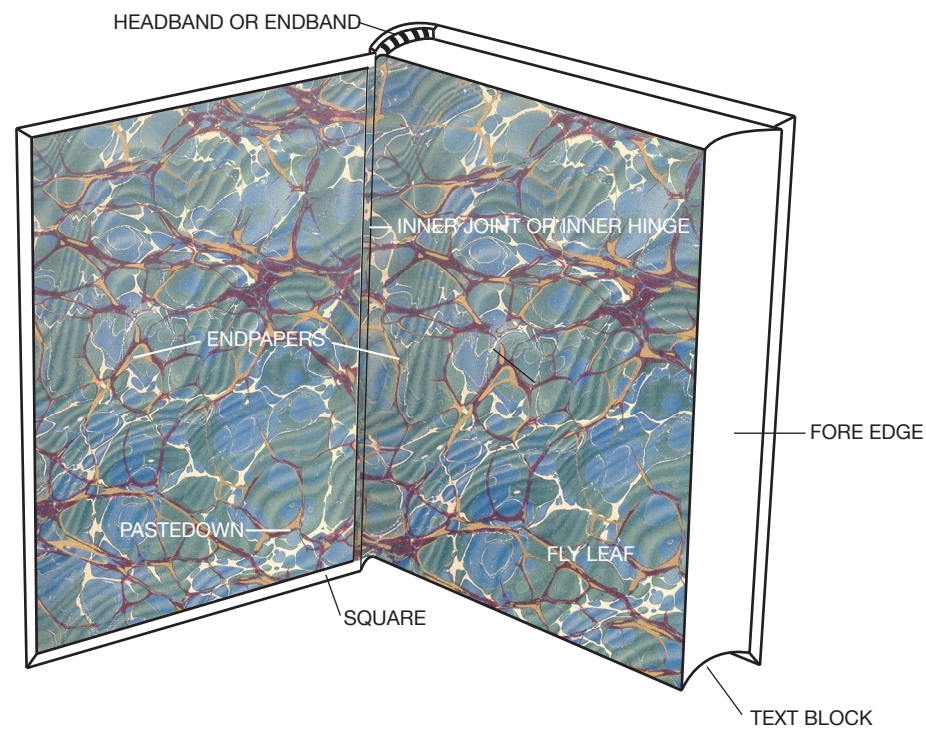
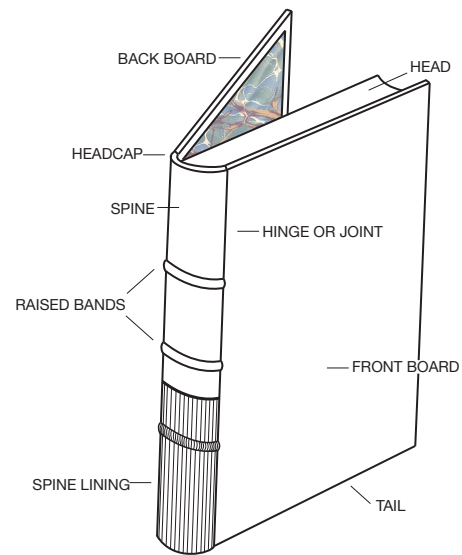

How Books Are Constructed

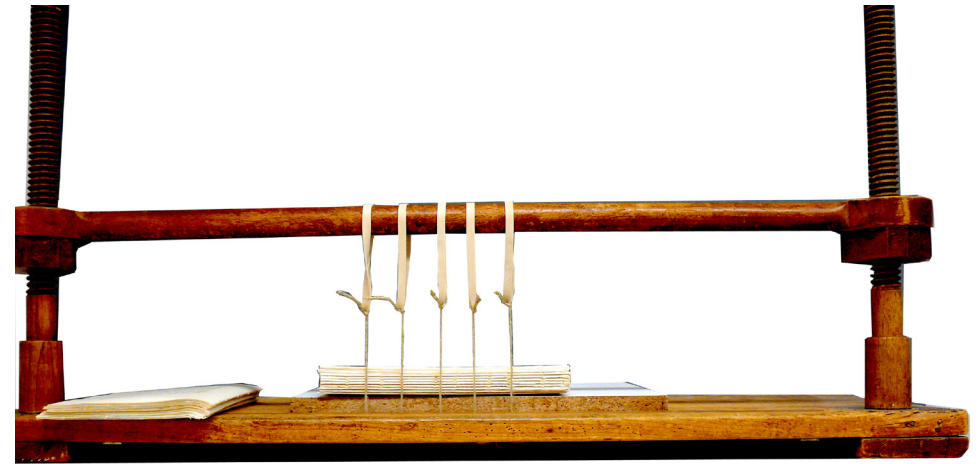

Books are sewn around supports using a sewing frame. This book is being sewn on cords.

When considering how best to care for the books in your home library, it is helpful to understand how books are made.

Western books are composed of sheets of paper or parchment that have been folded in half and gathered together into groups called sections. The sections are sewn through the centers of the folded sheets and joined in various ways. Sections may be linked together with knots, or the thread may pass around sewing supports.

This constitutes the text block. The text block may be reinforced with thin cloth and paper linings.

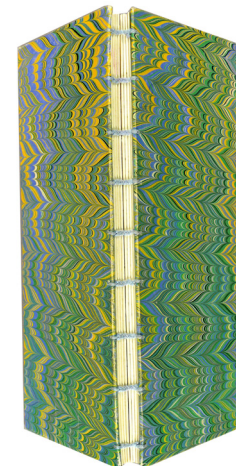

A model of Coptic binding. Sections are linked with knots, forming a chain stitch.

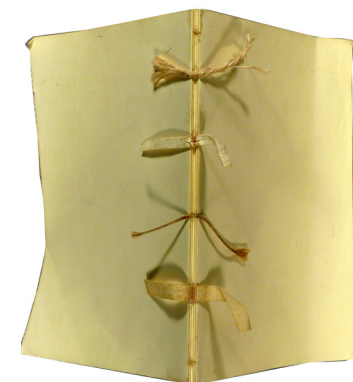

A model showing different types of sewing supports: raised cord, alum-tawed thong, woven tape, and recessed cord.

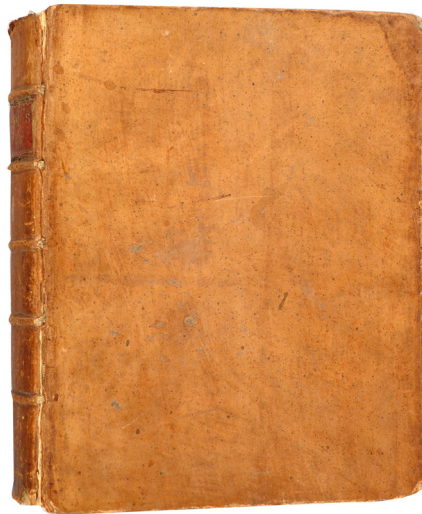

Full-leather, tight-back binding from 1781. The worn hinges reveal that the cords on the spine are laced into the boards.

The text block is inserted into the cover of the book. The cover may be as simple as a single sheet of paper, or it may be complex and heavily decorated. The cover is generally composed of two stiff boards made from laminated paper, millboard, wood, or even metal or plastic covered with paper, cloth, or skin (parchment or leather). Bindings are described as full, half, or quarter depending on the proportions of the covering materials. Full-leather binding describes a book bound entirely in leather.

The cover may be attached directly to the spine of the book (tight back). A hollow can also be left between the spine and the covering material.

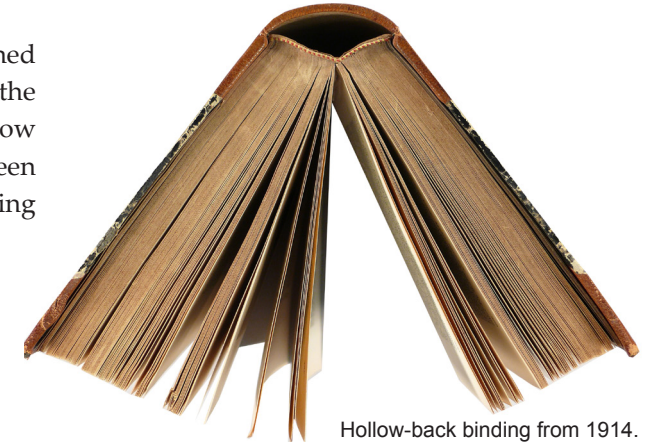

Hollow-back binding from 1914.



Tight back binding from 1976.

Asian books are produced in different formats. They may be composed of single or folded leaves sewn through the side, along with sheets of paper that serve as covers. The text block may also be an accordion fold.



Half-leather binding.



Quarter-leather binding.

Half-leather binding describes a book with a leather spine and leather corners, but with cloth or paper sides. A quarter-leather binding has a leather spine and sides that are cloth or paper.



Text block in concertina format (Chinese).

Caring for Your Books

The structure of the book fails when any of its components are damaged or wear out. Here are some suggestions for providing fundamental protection for your books.

Temperature and Humidity

Providing stable and optimal temperature and humidity is an important step in safeguarding your book collection.



Mold growth as the result of water damage. The paper has been stained by digestive enzymes released by the mold colony.

- High temperatures (above 72 degrees F) lead to desiccation and degradation of paper, cloth, and adhesives.
- Low temperatures (below freezing) can cause adhesive failure and condensation.
- High humidity may lead to the distortion of covers or text blocks when moisture is absorbed into the binding.
- High humidity (above 60 percent relative humidity [RH]) may also lead to mold growth, which will permanently damage cloth, leather, and paper. Inactive mold spores are all around us – in the air, carpeting and furnishings, and the dust on your bookshelves. Most indoor mold species will remain inactive until humidity exceeds 60 percent for a period of 24 hours. As mold grows, it digests its substrate, causing permanent weakening and staining of library materials. Consult the Cornell University Library Department of Preservation and Collection Maintenance Disaster Recovery brochure for more information about mold.
- Low humidity (below 30 percent RH) with normal or high temperatures may cause paper, cloth, and leather to become brittle.
- Low humidity may also cause cover distortion, particularly in vellum and leather bindings, because boards can warp due to a lack of moisture.
- Extreme fluctuations in temperature and humidity will also promote chemical reactions leading to the degradation of book materials.

Library materials benefit from being stored in an environment with a low temperature and low humidity; however, temperatures should be comfortable for people as well. Maintaining a consistent environment is most important. Books that experience improper temperature and humidity conditions for part of the year while in storage or due to seasonal fluctuations are likely to sustain damage in the form of fiber deterioration, adhesive failure, and mold growth even though they may have a good environment for the rest of the year. Decide what temperature and humidity settings you can comfortably maintain throughout the year.

Your home library probably contains a variety of materials such as books, documents, photographs, and works of art on paper. They have different tolerances for heat and humidity.

- The ideal conditions for a home library that contains a variety of materials are 65-72 ° F with 30-50 percent RH.

Temperature can be managed with heaters and air conditioners. Unfortunately, air conditioners may provide cool temperatures with high humidity. You can manage humidity by using humidifiers or dehumidifiers and providing good air circulation. Dehumidifiers must be emptied periodically, or they will support mold colonies. Most dehumidifiers can be set up to empty into a drain automatically.

Monitoring Temperature and Humidity

Several inexpensive temperature and humidity indicators are available from archival or electronics suppliers (see the suppliers list at the end of this brochure). Some have alarms that will alert you if the humidity exceeds a preset point. Inexpensive indicator cards are also available from archival suppliers. You may need more than one indicator per room. Be aware of micro-environments that may exist in corners or behind shelves.



Humidity indicator cards available from Gaylord.



Nitrile gloves protect against mold and chemicals, and do not contain latex.

Dust and Pollution

Dust not only abrades bindings and obscures text, it also contains mold spores. Periodically vacuuming or dusting your books will help prevent a mold outbreak. Because mold spores are extremely small, it's best to use a vacuum with a HEPA (high efficiency particulate air) filtration system with a brush attachment to vacuum bindings gently. HEPA filtration systems were originally designed in the 1940s for use in the Manhattan Project to prevent the spread of radioactive contaminants. Now, the systems are commonly used in homes to eliminate airborne dust and pollen.

HEPA filters can remove at least 99.97 percent of airborne particles that are 0.3 micrometers in diameter. Mold spores range in size from 1-200 micrometers in diameter. It is important that your vacuum cleaner have an enclosed system so that all of the expelled air passes through the HEPA filter. If you do not have a vacuum with a HEPA system, you can wipe dust off your books using "magnetic" wiping cloths that hold dust using an electrostatic surface charge. (Swiffer cloths are one commercial brand.)

Do not wipe your books with any cloth treated with wax, liquid, or perfumes; chemical additives may harm your books.

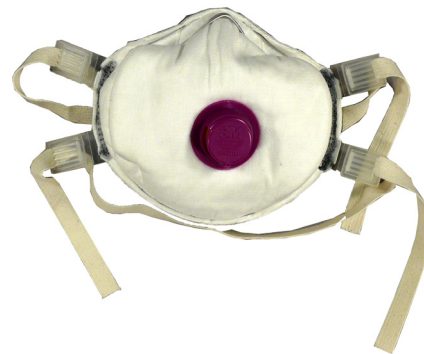

A disposable N95 respirator will filter out mold spores.

If your books are extremely dusty, you should wear protective clothing such as an apron, nitrile gloves, and possibly an N95 respirator and non-vented goggles to protect yourself from inactive mold spores.

See the supply list at the end of this brochure for vendors of these items.

Air pollution contains sulphur dioxide, oxides of nitrogen, ozone, and carbon dioxide, all of which may be absorbed into book materials and produce sulfuric acid and other acids. Try not to store books in the same room as a wood-burning stove. Cigarette smoke also contains gases harmful to books. Open windows may admit industrial air pollution, but if the outside air is clean, they will promote good air circulation. Make sure windows have screens to keep out dust and insects.

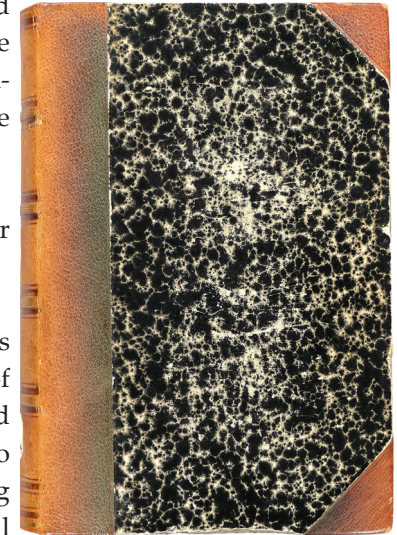

Light damage on a leather binding. The leather was originally green.

Proper Lighting

Although all light harms library materials, ultraviolet light is the most damaging. Light oxidizes dyes and inks in cloth, leather, and paper, causing fading and discoloration. The damage is more than aesthetic. Oxidation causes a breakdown of cellulose chains; in turn, that breakdown results in weakened paper and frayed cloth covers. Light exposure also accelerates the aging process in leather.

- Keep your materials out of the sunlight.
- Keep lights off as much as possible in areas where your books are stored. UV sleeves are available for fluorescent lights, but these wear out over time and need to be replaced.

Cleaning books

- Start with the top of the book:
- Hold the book upright, with one hand around the spine.
- Using the other hand, wipe or brush from the back of the book toward the front.
- Turn the book over and wipe or brush from the back toward the front.
- Wipe the fore-edge, the front board, the back board, and the spine.



Vacuuming a book using the upholstery attachment.

Shelving Books

Books up to 15 inches tall and of medium thickness should be stored standing upright. They should be shelved firmly together to give each other support, but not so tightly that they cause distortion. Books should also be stored in groups of similar height on shelves deep enough that they can be pushed back one or two inches away from the front edge. This will protect them in the case of an overhead water leak. Oversized books should be stored flat on shelves deep enough to accommodate their width. Leather books should not be stored next to cloth or paper books due to staining from oily or powdery leather.

Shelves should be located on inside walls, away from windows. Books should not touch walls. At least three inches should be left between the wall and the books. Avoid storing books in closed cabinets, due to the lack of air circulation.

- Shelves made from powder-coated steel or anodized aluminum are currently considered to be the safest storage options. If you are using wooden shelving, oak should be avoided. Wooden shelves must be sealed.
- Avoid shelves with oil or alkyd-based paints and sealants. Good ventilation is your best defense against damaging off-gassing.
- Evaluate storage areas for potential danger from water leaks. Avoid placing books under overhead pipes or under bathrooms.
- Be alert for potential roof and gutter problems.
- Avoid shelving books close to the floor. If this is unavoidable, consider investing in water sensors. There are inexpensive, battery-operated models that will set off an alarm when water puddles on the floor.



Bad shelving. If books are too tall for a shelf, they should be stored flat, not on their edges. These tall books also extend out from the shelf, putting them at risk in the event of a flood. This image also shows short books stored next to tall books.



Good shelving.

Predators

Insects such as silverfish, cockroaches, and book worms will eat library materials. You might find tiny, white insects known as book lice in the pages of your books. These insects do not eat cellulose but are attracted to mold, and they are an indication that the relative humidity is too high. Many people store books and papers in boxes in their basements,



Insect damage.

but corrugated cardboard boxes are favorite residences and hiding places for insects and mice. If books are stored in a damp basement, cardboard also helps provide the moisture that all living creatures crave. To prevent insects and vermin from feasting on your collection, eliminate their hiding places and food sources.

Consider using good-quality plastic storage totes with tight-fitting lids for storing books. Check them regularly for condensation or signs of mold.

- If you need to store materials in corrugated boxes, re-house them periodically.
- If you are storing books and other materials in your basement or other non-living areas, keep the humidity low. Use a dehumidifier if necessary.

Handling

When you are removing books from a shelf do not pull down on the spine because the spine piece is easily torn. Instead, push in the books on either side, leaving the selected book sticking out. Use two hands, placing one underneath the book as you remove it from the shelf. This is particularly important when removing scrapbooks, because they often have loose items tucked inside. If the book is very large or heavy, place one hand at each end of the book.



Spine piece torn by pulling on the head-cap.



Push in books on either side of the one you want.

Keep food and drinks away from your books. Do not use books as coasters; stains from food and drink are irreversible, and food residue will attract insects and vermin.

Photocopying

When photocopying books, do not open them wide and press down hard. That could break the glue and linings of the spine, causing a fracture at that point in the book. It will also damage the sewing, causing the book to be at risk for loose leaves.

Ink, Paper Clips, and Other Office Products

Avoid underlining text in your books, particularly with permanent marker. Do not insert sticky notes or paper clips to mark pages. Sticky notes may get lost between the pages and become permanently adhered and plastic or metal paper clips can damage the paper. And, of course, do not turn down the corners to mark your place. Use long strips of good quality paper to mark your place; they won't damage the paper or get lost in the book.

Types of Books and Their Inherent Weaknesses

Books are often categorized by their binding styles, and most of us have a variety of bindings in our home library. Each of the binding categories listed below have weaknesses that may require extra attention specific to the materials and structure of that binding. This is a very brief overview of bookbinding. To learn more about the history of bookbinding, consult the bibliography at the end of this brochure.

Paperbacks

In 1935 Penguin Books introduced paperback books in Britain. Although paperbacks are sometimes sewn with thin thread using knots to hold the sections together, they are often single sheets glued together, or “perfect bindings”. A decorated paper cover is attached using the same adhesive. They are cheaply produced and not expected to last long. They are often taken to the beach or read while riding public transportation, and they are usually printed on poor-quality paper that yellows early. It's worth noting that publishers have started using the same technique of gluing rather than sewing

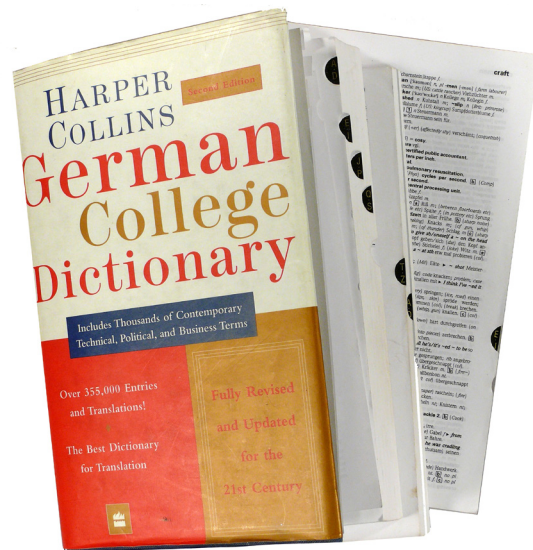

A dictionary purchased in 2003. It has been glued rather than sewn.

the text block on many hardcover books issued today. If you look at the books from the top, the folds of the signatures are visible, and you might assume they are sewn in sections. After printing, however, the folds have been cut off and you will look in vain for the thread that would have been there if the book had been sewn.

These books will often break when opened wide. When pressed fully open, the glue often fails and the text block falls apart, because there is no sewing to hold it together. Paper covers are fragile and tear easily. These bindings are also particularly vulnerable to the stresses of photocopying and being left open with the pages facing down.

Cloth-Case Bindings

Most of us have modern case bindings in our collections. These include children's books, cookbooks, diaries, reference books, and most hardcover books. Modern case bindings are constructed from laminated paper boards covered by a plain, sturdy cloth or decorated paper. The cover, or “case,” is made separately from the text block and attached by gluing the endpapers to the inside of the case.

Cloth was first introduced as a covering material in the 1820s. Around this time, the technique of making the cover of the book separately from the text block was developed in the West. These two developments led to the mechanization of the bookbinding process. In 1903, the casing-in machine was invented, and by the beginning of the 20th century, all aspects of book binding were mechanized. Within a few years, publishers started issuing books with brightly colored endpapers and elaborately decorated and stamped covers. These are known as Victorian cloth bindings, and they were prevalent from the 1820s through the early 1900s.

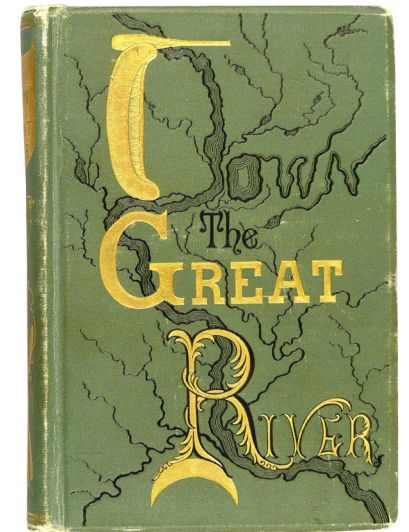

Cloth case binding published in 1893.

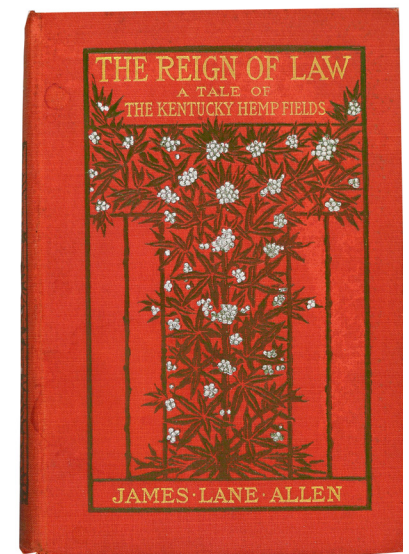

Cloth case binding published in 1900.

In the late 19th century and early 20th century, publishers contracted with artists to design not only the covers, but also the typeface and look of the book. This was the beginning of graphic design. Dust jackets became prevalent in the 20th century, as the Victorian cloth binding era ended. As dust jackets became more popular, cloth bindings became more plain and utilitarian.



Cloth case binding published in 1963.

Because the case is attached to the text block simply by gluing it to the endpapers, rather than by lacing the sewing into the boards as with early bound books, the joint attachment may be weak. There is a space between the spine piece of the binding and the back of the book that allows these books to open flat, but it puts stress on the sewing. Because machines perform many steps of the binding process, and the binding materials are often of inferior quality, early mechanical failure may result. A common failure of case binding is the detachment of the case from the book block. The spine piece also can tear and even come off completely, sometimes leaving the boards still attached. Although cloth can be more durable than leather, cloth will deteriorate when exposed to sunlight, and it will fray and tear with use. Thin cloths wear easily, exposing corners and edges of the boards.

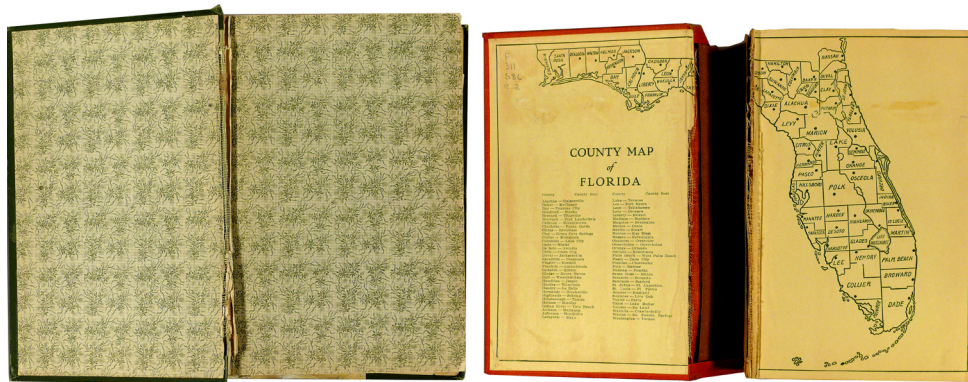

Inside hinge of cloth-case binding.

Inner hinges may come completely detached.

Paper Bindings

Paper bindings are temporary bindings issued by printers and have been in use since the 15th century. These bindings have simple paper covers that sometimes have publishing information printed on them. Older paper bindings may be covered with marbled paper. They are different from the paperbacks described above, because paper bindings are considered to be temporary – not permanent – bindings. Paper bindings are issued in sections rather than single sheets so that they can be taken apart and sewn properly when they are rebound. Paper bindings are meant to be bound later in a style chosen by the book purchaser. People often had all the books in their libraries bound in a particular way.

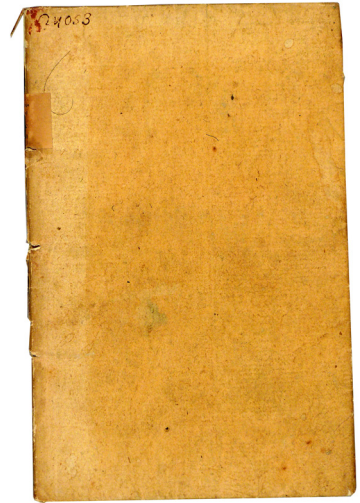

Paper binding on a book printed in 1810.

Although the paper used for covers in early paper bindings can be quite sturdy, paper used during the 19th century and after is generally very fragile and often acidic. The sewing is also weak, because it was considered temporary when the book was produced and often used only two sewing stations rather than the usual five.

Leather Bindings

Leather has been used to cover books since the 3rd century A.D. Although leather was the most prominent covering material before 1826, it is now used primarily for special editions. A leather binding may have its covering material adhered directly to the spine of the book. This gives the book more support, but when the leather deteriorates, it can discolor and damage the folds. A leather binding might also have a hollow back, a structure that allows elaborate spine decoration and facilitates a wide opening. Leather comes in many colors and is commonly made from goat, sheep, or calf.

Although leather bindings from the 3rd through the 17th centuries are generally stable and not prone to deterioration, later bindings are not as stable. As the demand for books became greater and resources for tanning became scarcer, tanners were forced to use take shortcuts and use materials less resistant to atmospheric stresses. Deterioration of leather is partly caused by oxidation and acid hydrolysis of leather tannins. Atmospheric pollutants such as ozone, sulphur

dioxide, and nitrogen dioxide react with leather tannins to form sulfuric acid and other acids, and they begin to break down chemical bonds in leather. Sunlight also contributes to these chemical reactions. Heat, moisture, and low pH hasten the breakdown of collagen fibers in the skin itself. As leather deteriorates, it becomes brittle and powdery. In cases of severe deterioration this powder is extremely thick and almost oily. This is known as “red rot,” and it is notorious for its smell and the rusty red powder that coats your hands and clothes as you handle the book.



Red rot smears easily and will damage other books.

Parchment or Vellum Bindings

The manufacture of parchment dates back to approximately 2000 B.C. It was the most important writing material of the Middle Ages and was also used to cover early bindings. Parchment or vellum (the two terms are used interchangeably) is made from the skins of sheep, goats, calves, or other small animals. The animal skins are soaked in an alkaline solution (dehaired), and then stretched and dried under tension. Parchment differs from leather because it has not undergone the chemical change caused by tanning. Although new parchment is white, it becomes beige or greenish as it ages. Parchment is extremely thin and hard. Some parchment bindings are categorized as “limp,” meaning they are bound without hard boards.

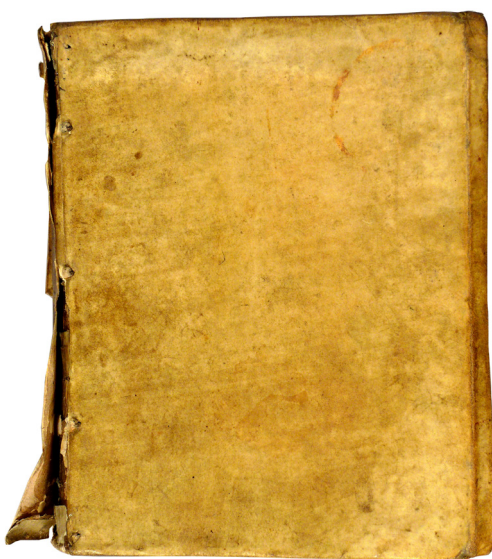

Parchment is very sensitive to changes in humidity and will contract tightly as the humidity goes down. When used on a book with boards, it may cause the boards to curl, and the book will become misshapen. As the parchment cover contracts, it may force the joints to crack. In some cases, the shrinkage is so severe that the binding may no longer fit the book.

Vellum binding on a book printed in 1619. The joints in vellum bindings are often torn.

Family Bibles

Many people have family Bibles. Some have editions that are 100 or 200 years old with very ornate full-leather bindings. People often wonder if these older copies are valuable as collectables. According to the Antiquarian Booksellers Association of America (ABAA), the Bible is the most printed book in history, and many copies have survived; therefore, even though your copy might be quite old, it is probably not valuable. Some valuable editions of the Bible do exist, however, including the so-called “Breeches Bible” or Geneva Bible of 1560, in which the clothing Adam and Eve put on is referred to as “breeches.” The first edition of the King James Bible is another example of a valuable edition of the Bible.



A family Bible published in the 1870s. These ornate, leather editions of the Bible were sold by subscription.

Although they are not valuable in a collectable sense, family Bibles may contain genealogical information that is valuable to your family. This is usually found between the Old and New Testaments.

Since family Bibles are mass-produced, their materials are generally inferior. The paper is often acidic or brittle, and the cloth or leather used for the binding deteriorates quickly.

Scrapbooks

Scrapbooks come in all sizes, materials, and formats. Any blank book can become a scrapbook when a variety of materials are glued or laid into it.

Like family Bibles, books used to construct older scrapbooks are generally mass-produced, and their materials are inferior. It is very common to find yellowed, acidic newspaper clippings glued into a scrapbook with heavy, brown animal glue. By placing loose ephemera into a blank book, you distort and weaken the binding, the same way it would if you placed office products within the binding.

This does not necessarily include books and other materials currently being marketed for the hobby known as “scrap booking.” Materials being manufactured for this purpose are generally archival (although it’s worth checking the labels), and modern scrapbooks have stubs that allow for inserting ephemera.

Repairing Books

What If Your Books Need to Be Repaired?

In most cases, you should consult a book conservator before attempting your own repairs. If you have any questions about what can or should be done, please contact the book conservator in the conservation unit of the Department of Preservation and Collection Maintenance in Olin Library. You may email conservation@cornell.edu or call (607) 255-2484. We would be happy to meet with you and examine your book to offer advice. Another resource is the American Institute for Conservation (AIC) listed at the end of this brochure. Its Web site includes a “find a conservator” tab.



Using masking tape has destroyed this binding. It will have to be rebound.

Does Repairing a Book Diminish Its Value?

This is sometimes a concern when evaluating whether you should repair a book in your collection. First, consider whether its current condition prevents you from reading and enjoying it. If you are unable to handle the book and want to read it, then fixing it will most likely enhance its value as long as the repair you are considering utilizes good materials and competent workmanship. Finally, consider its date of publication. If it is a book published before 1820, repairing or rebinding it should not diminish its value because it was most likely issued in a temporary binding, and its current binding is not relevant to its publishing history. Replacing a binding contemporary with the date the book was issued with a modern binding can be problematic, however. For example, if the book was published in 1520 and was bound around that time in parchment, replacing that binding with a modern cloth case will most likely diminish its



Poor quality self-adhesive tape damaged this page.

Terms

- **Acid or acidic:** has a pH below 7 (neutral). Acidic materials tend to deteriorate more quickly than neutral materials.
- **Acid-free:** has a pH of 7 or higher. A material is acid-free if it has a neutral pH at the time of manufacture.
- **Base or basic:** has a pH above neutral. Materials above 8.5 may be corrosive.
- **Buffer:** a basic chemical added to protect against acidity. Paper buffered to 8.5 will resist corrosive effects of acids in the environment more effectively than a paper that has a neutral pH (7). It's best to use buffered paper for book enclosures or inserts.
- **Reversible:** removable. Materials used to repair rare or valuable books should be easily reversed. Some archival tapes and adhesives are only reversible using solvents that require careful handling and should not be used on rare materials.
- **Non-reversible:** not removable. A self-adhesive tape may be archival, meaning that it will not stain or corrode over time, but may not be reversible. No self-adhesive tapes are easily removed.
- **PVA:** polyvinyl acetate, also known as white glue. Elmer's Glue is a poor-quality PVA that will yellow and become brittle with age. Archival quality PVA is sold by archival suppliers and scrap booking suppliers. Archival PVA will not deteriorate, but it is also not reversible and should not be used on rare materials. Although manufacturers may claim some PVA is reversible, studies have shown that this is not the case after the glue has been dry for a few months.

value. Repairing or rebinding a publisher's binding printed after 1820 is also likely to decrease the value of that book, because you would be changing an original component of the book. If you have concerns about the resale value of books in your library, consult a rare books dealer.

Do-It-Yourself Repairs

Although it's best to consult a conservator before trying to make repairs yourself, you can undertake minor repairs on books that aren't valuable by using care and good materials. Repairs with poor workmanship or materials may destroy your book.

- Use repair materials from reputable archival suppliers and understand there is a difference between acid-free and archival. “Acid-free” refers to the pH of the material at its time of manufacture. Some so-called “acid-free” materials can quickly become acidic, or stain or otherwise damage your book. “Archival” describes long-lasting materials that will not damage the artifacts being repaired.

Common Forms of Damage: What You Can Do About Them



Pressing a book between boards. The spine of the book should not be between the boards.

Misshapen Boards

When books are shelved improperly or not shelved at all, the boards may curve inward or outward, sometimes dramatically. You may be able to reshape a book by putting it under a moderate weight for several days. Put a board or a larger book between the weight and the book to be flattened. Books should be stacked alternating spine to fore edge. In the case of severe board distortion, you may have to consult with a conservator.

Torn Pages

The best repair for a torn page is to reattach the torn surfaces and cover the tear with a thin Japanese tissue, such as usumino or kizukishi, using a reversible adhesive such as wheat starch paste. Paste the edges of the tear, stick them back together, then paste a narrow strip of tissue over the tear. Let it dry under blotting paper and a light weight. Starch paste should be fresh and made from distilled water and pure starch. Some pre-made pastes contain fungicides or other additives and should not be used on rare materials. Using starch pastes also poses risks of staining or distortion. If you are not familiar with starch paste, your best option is to repair the tear with archival document repair tape (see the suppliers list at the end of this section for vendors). Document repair tape should not be used on rare or collectable materials, but it is appropriate for books that are used frequently and can be replaced, such as children's books, dictionaries, or cookbooks. Cut the tape into narrow strips.

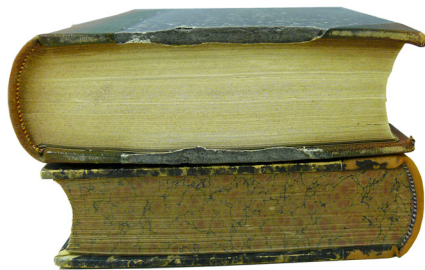

Stacking books fore-edge to spine will help press them back into shape.

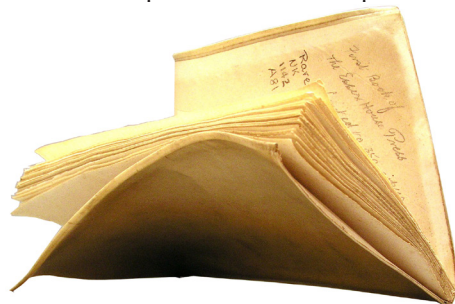

This vellum binding was not properly shelved, and the boards have warped as a result.

Loose Pages

Loose pages can be reinserted by putting a very narrow line of adhesive (paste or archival PVA) on the edge and putting the page back into its rightful spot.

This is called "tipping in." Loose pages may be tricky, because you have to first determine whether they are half of a folded leaf. Remember that text blocks are assembled by sewing through the centers of folded sections. However, illustrations are usually single sheets that have been added separately and these often come loose. If you determine that the loose page is not part of a

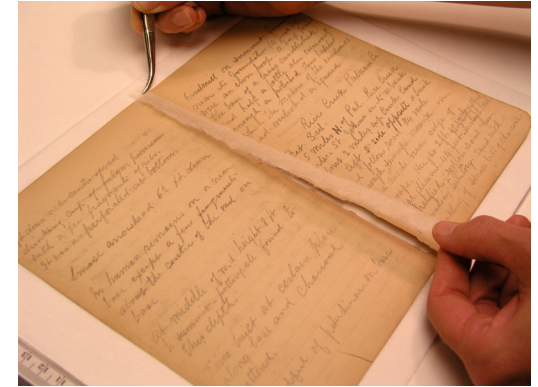

A folded sheet with a center fold and tears repaired with Japanese tissue.

folded section, apply adhesive in a thin line on the edge and stick it back into place. If it is half of a folded leaf, the entire section will have to be removed, repaired, and sewn back into the book. This should be done by a conservator. Do not tip more than two loose sheets together. Consult a conservator if you have any doubts.

Paperback bindings will often split apart at the spine, and many of the pages will loosen and fall out. If this happens, all the spine adhesive must be cut off and the spine glued again. The original cover can be pulled off before this procedure and then reattached. It is possible to cut and reglue a paperback as long as the inner margin is generous. A book conservator or commercial binder can perform this type of treatment.

Acidic Paper

Historically, paper has been made from macerated plant fibers. It is naturally slightly acidic. As paper becomes more acidic, it becomes discolored and brittle. Conservators use a "folding test" to determine how brittle a page has become: i.e. one corner of the page is folded backward and forward, and then tugged gently. If the corner breaks off, the paper is dangerously brittle. Paper deteriorates this way because of the presence of lignin in its manufacture. Lignin, which is found in ground wood pulp, reacts to bleaching and pulping processes by becoming brown and brittle. This process is exacerbated by exposure to light, high temperatures, and humidity. As an example, notice how quickly newspapers turn yellow when left in the sun.

When paper was first produced, it was made from linen and cotton rags. As the book trade expanded, demand for paper increased to the point that many kinds of materials were used. Ground wood pulp containing lignin was added to paper during the 1850s as a cheap alternative to linen or cotton rags. It took a

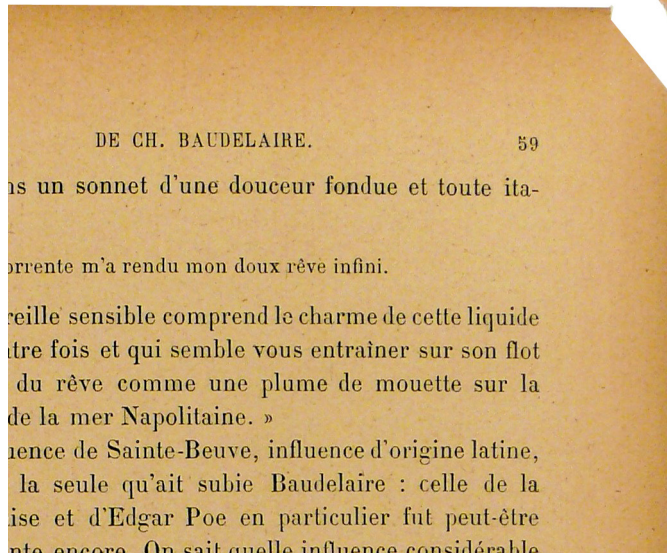

This page has failed the brittle paper test.

few decades to realize its detrimental effect on the appearance and flexibility of paper. In the 1950s, scientists discovered that adding calcium carbonate during the paper-making process helps offset the effects of lignin deterioration. Paper produced from the 1850s through the 1950s is likely to be dangerously brittle. At its worst, brittle paper will break off at the section folds. Pages may fracture and text may be lost. It may be impossible to repair these pages because they will break off next to the repair. Unfortunately, many beautiful Victorian cloth bindings have brittle paper.

People often ask if they can treat acidic paper chemically. It is possible to spray acidic paper with a solution that will neutralize and buffer the acid, and this may slow down the rate of deterioration. Bookkeeper Deacidification Process, manufactured by Preservation Technologies, is currently the most popular of these solutions and sold by a number of archival suppliers. Unfortunately, it will not restore paper's flexibility. If your book has brittle paper but is holding together, one solution is to put it in an archival enclosure and only handle it occasionally and carefully. Another option is to photocopy the text and have the copy rebound as a usable copy, saving the original in a box. In the instance of genealogical pages from a family Bible, it's best to photocopy them so that the Bible doesn't have to be opened repeatedly. This is also a good solution for newspaper clippings in a scrapbook.

Foxing

The orange or rust-colored speckles you sometimes see in paper are known as foxing. Conservators debate whether foxing is a form of mold or caused by iron impurities in the paper, but it seems to be a combination of both, and high humidity exacerbates

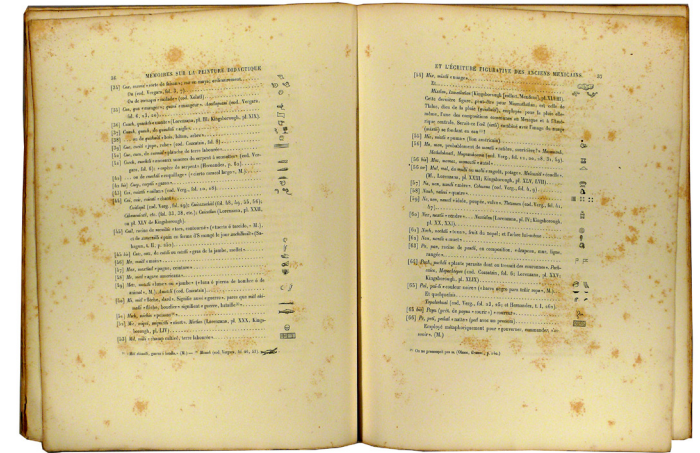

Foxing.

it. Bleaching can remove the spots, but it will not improve or strengthen the paper. Maintaining low temperature and humidity well help prevent foxing from worsening.

Musty Smell

A musty or moldy smell, particularly in books that have been stored in a basement, is a common concern. It is an indication that active mold, visible or microscopic, exists in these books. Dehumidification should remove the odor. If the books are stored in a container, remove them, stand them up with the pages open, and put them in a room with a dehumidifier. The odor should disappear with increased air circulation and low humidity, although it may take days or weeks. If it's practical, you may put the books in the sun for a very short period of time, but remember that sunlight is damaging to books in the long term. Reducing humidity will kill growing mold and return the mold spores to their inactive state.

Another technique is to construct a sealed chamber out of medium-sized and large plastic containers, such as garbage cans. Punch holes in the smaller container and place the books inside. Put some odor-removing material – such as baking soda, unscented cat litter, or charcoal – in the bottom of the larger container and place the smaller container inside the larger container, on top of the material. Place a tight-fitting lid on the larger container. Check periodically to see if the odor has dissipated and make sure there is no condensation.

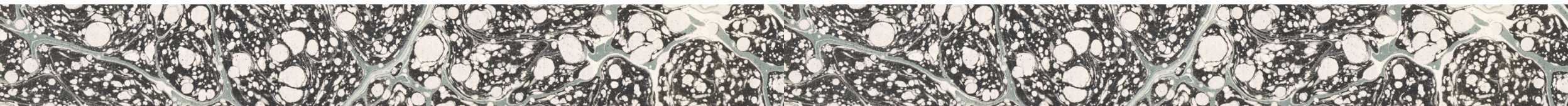

Mold

It is impossible to remove all inactive mold spores from your environment – which means there is always a risk that mold will develop in areas of high humidity and on surfaces that are continually wet. If you suspect mold is growing in your materials, first lower the humidity to make the mold inactive. You may want to call a conservator for professional advice. Because mold may be toxic and irritate allergies, be cautious when dealing with it. When examining materials you suspect might be contaminated with mold, wear proper protection, such as gloves, an apron, non-vented goggles, and a N95 respirator. (Disposable models are readily available and inexpensive.)

Cleanup can begin as soon as active mold colonies have dried up. Small amounts of inactive mold can be vacuumed or wiped with a cloth, as described in the section on cleaning. Bindings and text block edges may be wiped with 70 percent alcohol using cheesecloth that has been wrung out well. Consult the Library's Disaster Recovery brochure for more information about personal protective equipment and coping with mold damage. Additional resources are listed at the end of this booklet.

Dirt and Soot

Clean as described in the "Dust and Pollution" section of this booklet. Surface dirt may be cleaned with a vinyl eraser or a soot sponge, which are also known as dry cleaning sponges. These blocks of vulcanized rubber are sold at archival suppliers and hardware stores, and they work well at picking up dirt over large areas.



A soot sponge easily picks up dirt from the top of this book.

Staining

Stains on paper or cloth are difficult to remove; consult a conservator. Unless a book has resale value, it's best to consider stains part of the book's history and leave them alone. Stain removal is an invasive treatment that may compromise the artifact.

Broken Spine

When a book is opened too widely or too quickly, the spine linings may break. If the book is a tight-back, the covering material will break as well. The spine

will need new linings, and the binding will probably need a new back. Talk to a conservator before attempting repair.

Worn Corners and Edges

As the covering material on corners and edges wears, the board is exposed and may delaminate. You can carefully insert a small amount of paste or PVA between the layers to smooth and consolidate them. Frayed threads may also be tacked down. Consult a book conservator if you want to replace the material covering the corners and edges.

Torn Spines, Joints, or Hinges

All books are likely to develop weaknesses at their joints, because these areas take the most stress. The boards may become completely detached from the rest of the binding, or the cover of a case binding may completely detach from the text block. Always talk to a conservator before attempting a repair. If the inside joints are cracked but not torn, they may be reinforced with a narrow strip of thin Japanese tissue using wheat starch paste. When the spine of a hollow-back book becomes detached, it is tempting to glue the spine piece directly to the back of the book with PVA, but this will inhibit opening and prevent a proper repair in the future.

Dry Leather and Red Rot

The leather aging process has been researched and discussed for many years. In the past, many leather dressing formulations have been recommended to counteract leather deterioration. Rubbing some sort of oil on dry leather bindings is immediately gratifying, because the book looks newer and more lustrous; unfortunately, people often apply leather dressings too thickly

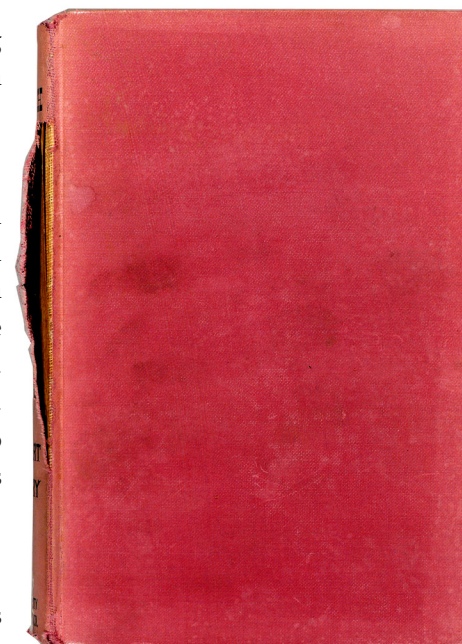

A torn outer hinge.

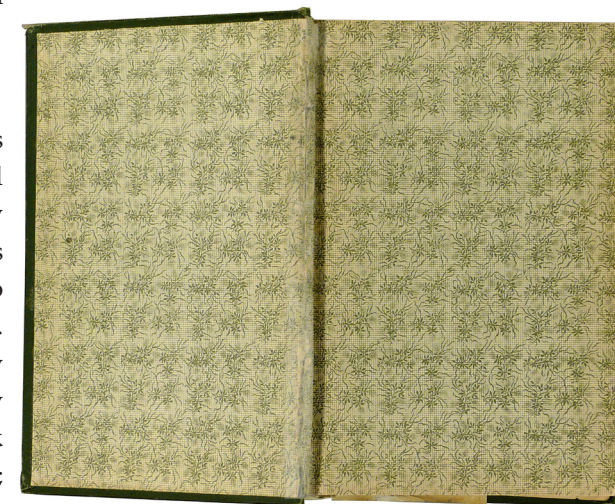

A weakened inside joint reinforced with Japanese tissue.

and too often, and the oil from the dressing may soak through the boards and into the paper. Also, it's doubtful that applying a dressing actually restores the leather. Recent research conducted by the Leather Conservation Centre in England concludes that once leather has reached the desiccated stage, it is impossible to restore it. It can be consolidated to prevent more flaking.

Conservators recommend that dry leather be treated with a cellulose product (hydroxypropyl cellulose) mixed with isopropyl alcohol. Cellugel, a pre-made mixture of the two substances, is available from archival suppliers. A light coating may be applied with cheesecloth in a well-ventilated area and allowed to dry thoroughly. If the leather is extremely powdery, several coats may be necessary.

Once the leather has been consolidated, it benefits from having an acrylic wax applied as a surface coating. One appropriate wax, SC6000, is available from bookbinding suppliers such as Talas. (Its address is included in the suppliers list at the end of this pamphlet.) SC6000 is applied as a thin coating using cheesecloth, allowed to dry, and then buffed. This coating will protect leather bindings from airborne pollutants and slow down further deterioration. Leather bindings that have not deteriorated at all may benefit from the traditional leather dressings sold by suppliers of archival materials.

Water Damage

Spills of any sort require immediate action. If a book is allowed to stay wet for more than 24 hours, mold spores will start to germinate unless the book is drying in a well-ventilated area. If a few books become wet, stand them up, open the pages, and allow them to dry near a fan. The pages will become wavy or "cockled" and possibly water-stained, but this is unavoidable. When the pages are dry, close the book and place it under a weight for up to a week to reshape and flatten it. Consult the Library's Disaster Recovery brochure or call the Department of Preservation and Collection Maintenance for more information.

Enclosures

Consider using enclosures for books that are fragile or damaged, as well as those that have red rot or clasps or other protuberances. Enclosures protect books at risk, and they are better alternatives than a poor repair. If you have a damaged book but don't want to invest in a repair by a conservator or risk compromising the resale value of the book, you can stabilize the book with an inexpensive enclosure. You

can buy pre-made boxes from archival suppliers, buy or construct simple folding boxes known as phase boxes or marginal materials cases, or contract with a book conservator to make a custom-fitted clamshell box. In each case, you are providing a microclimate for that particular book and protecting your other books.

You can download instructions for constructing several types of enclosures from the Department of Preservation and Collection Maintenance Web page: library.cornell.edu/preservation.

Damage to More than 10 Books

If many books are damaged by fire, water, or mold, you may need immediate professional advice. Call the conservation unit of the Department of Preservation and Collection Maintenance at (607) 255-2484 for assistance. For more detailed information about mold mediation and recovery from a water disaster, consult the *Disaster Recovery: Preventing Water and Mold Damage* brochure published by the Department of Preservation and Collection Maintenance. You can also contact any of the organizations listed at the end of this brochure.

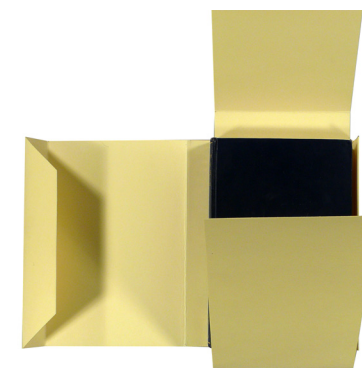

Phase box or marginal materials case. Instructions for making this can be found at library.cornell.edu/preservation/index.html



Clamshell boxes are constructed using binder's board and sturdy cloth.



Clamshell boxes are engineered to fit a book exactly.

Suppliers

This is a selected list of suppliers and not intended as an endorsement. Catalogs are free upon request.

For archival supplies:

Conservation Resources International, Inc.
5532 Port Royal Road
Springfield, VA 22151
800-634-6932
www.conservationresources.com

Gaylord Bros.
P.O. Box 4901
Syracuse, NY 13221
800-962-9580
www.gaylord.com

Hollinger Corporation
P.O. Box 8360
Fredericksburg, VA 22404
800-634-0491
www.hollingercorp.com

University Products
P.O. Box 101, 517 Main Street
Holyoke, MA 01041-0101
800-628-1912
www.universityproducts.com

For bookbinding supplies and books on how to bind and repair books:

Talas
330 Morgan Ave
Brooklyn, NY 11211
Phone: 212 219-0770
www.talas-nyc.com

For personal protective equipment:

Lab. Safety Supply
1-800-356-0783
www.labsafety.com

Additional Reading

History of bookbinding:

Jane Greenfield *ABC of Bookbinding*. Oak Knoll Press and the Lyons Press, 1998.

Middleton, Bernard. *A History of English Craft Bookbinding Technique*. Hafner Publishing Company. New York and London, 1963.

Ikegami, Kojiro. *Japanese Bookbinding. Instructions from a Master Craftsman*. Wetherhill, Boston and London, 1986.

Repair of books:

Johnson, Arthur W. *The Repair of Cloth Bindings*. Oak Knoll Press, New Castle, DE. 2002

Kite, Marion and Thomson, Roy. *Conservation of Leather and Related Materials*. Oxford; Burlington, MA : Elsevier Butterworth-Heinemann, 2006.

Care of your home library:

Balloffet, Nelly and Hille, Jenny. *Preservation and Conservation for Libraries and Archives*. ALA Editions, 2004.

DePew, John N. *A Library, Media, and Archival Preservation Handbook*. Santa Barbara, Calif.: ABC-CLIO, c1991.

Greenfield, Jane. *The Care of Fine Books*. New York, NY: N. Lyons Books, c1988. [Distributed by Lyons and Burford.]

Ogden, Shereilyn, ed. *Preservation of Library and Archival Materials: A Manual*. Andover, MA: Northeast Document Conservation Center, 1994.

Updated pamphlets from this manual are also available on line at the Northeast Document Conservation web site.
www.nedcc.org/leaflets/leaf.htm

Resources

American Institute for Conservation
1156 15th Street, NW
Suite 302
Washington, DC 20005
202-452-9545
www.conservation-us.org

Information on preserving family collections and finding a conservator.

Antiquarian Booksellers' Association of America (ABAA)
www.abaa.org/books/abaa/abaapages/faqs
Links to antiquarian book sellers who may be able to provide information on the value of books in your collection.

Department of Preservation and Collection Maintenance
B-32 Olin Library
Cornell University
Ithaca, NY 14853
607-255-2484
www.library.cornell.edu/preservation
E-mail: conservation@cornell.edu
Publications and manuals that give instruction in book repair, enclosure making, care of library materials, and disaster recovery.

Guild of Book Workers
521 Fifth Avenue
New York, NY 10173-0083
www.palimpsest.stanford.edu/byorg/gbw
Information on education, services and supplies for the bookbinding community.

Credits

This brochure was written by Michele Brown, book conservator, and produced by the Cornell University Library Department of Preservation and Collection Maintenance as a public service. The preservation procedures described are considered appropriate at this time. Procedures are re-evaluated as new information becomes available.

This brochure was designed by Jenn Colt-Demaree and Carla DeMello. It was edited by Gwen Glazer.

The "Parts of the Book" illustration was created by Kate Brown. This illustration was adapted from a drawing by Jenny Hille.

The photographs included in this brochure are of books in the Cornell University Library collection and from the personal collection of Frank and Michele Brown. Image of the Family Bible, 1870s, is from an online exhibition sponsored by the University of Pennsylvania. "Agents Wanted": Subscription Publishing in America. Philadelphia Area Consortium of Special Collections Libraries: 25 November 2008. www.library.upenn.edu/exhibits/rbm/agents

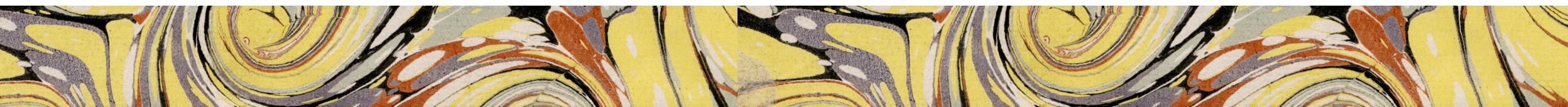



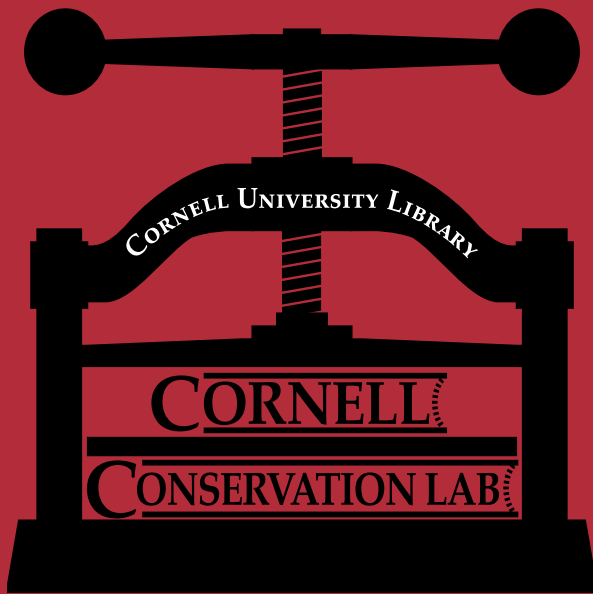

CORNELL UNIVERSITY LIBRARY

CORNELL

CONSERVATION LAB